

T46JRT

TELESCOPIC BOOM LIFT



- Mid-size diesel telescopic boom lift
- Features a jib boom for additional manoeuvrability
- Oscillating axle and 4 wheel drive for excellent rough terrain performance
- Simple to operate and maintain
- Ideal for construction and industrial applications

 **snorkel**
www.snorkellifts.com

TELESCOPIC BOOM LIFT

T46JRT

DIMENSIONS	T46JRT
Max. working height	16.0m
Max. platform height (A)	14.0m
Max. working outreach	12.2m
Platform size	2.44m x 0.91m
Overall width (B)	2.4m
Stowed length (C)	8.6m
Stowed height (D)	2.4m
Wheelbase	2.44m
Ground clearance	360mm

PERFORMANCE	
Platform capacity	227kg
Max. drive height	14.0m
Max. wind speed	12.5m/s
Max. drive speed (stowed)	7.25km/h
Max. drive speed (elevated)	1.1km/h
Jib length	1.8m
Jib arc	136°
Platform rotation	150°
Turret rotation (continuous)	360°
Raise/lower time	64/64 sec
Gradeability	40%
Inside turning radius	1.37m
Outside turning radius	4.57m
Tyres	355/55 D625 high grip, foam-filled
Controls	proportional drive, raise and slew
Drive system	4 wheel drive with oscillating axle

POWER	
Power source	Kubota V1505T diesel 44.2hp
Auxillary power unit	12V DC

WEIGHT	
Weight	7,030kg

WORKING ENVELOPE

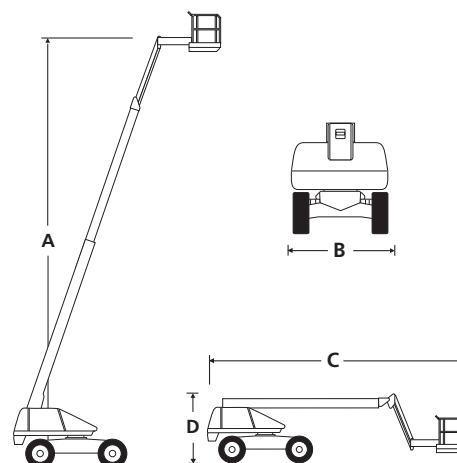
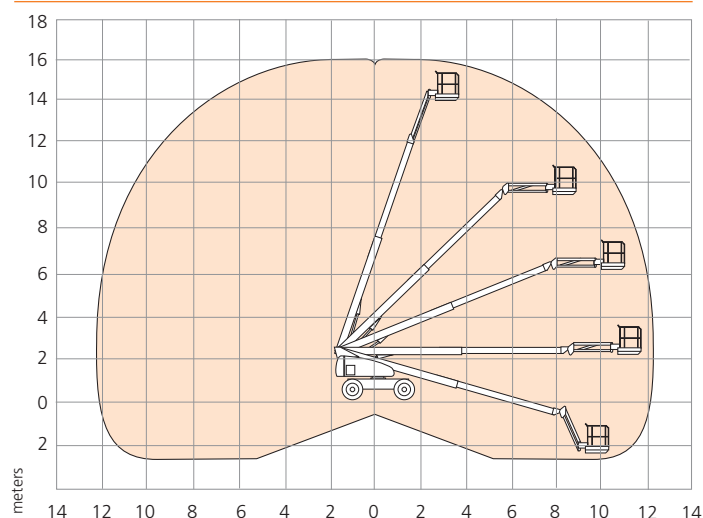

STANDARD FEATURES

- Snorkel Guard™ secondary guarding system
- 4 wheel drive
- Oscillating axle
- Swing-out engine tray
- Tilt alarm and cut-out
- Horn
- Power line to platform
- Proportional controls
- Hour meter
- DC emergency operation
- Tri-entry platform
- Flashing amber light
- 2 year parts & labour, 5 year structural warranty
- CE approved

OPTIONS

- Special paint colours
- AC generator 110V/240V 2kW
- Airline to platform
- Aircraft package
- Deluxe aircraft package
- Cold weather package
- Extreme cold weather package
- Extreme environment package
- Light package
- Glazier package
- 12k generator package
- 12k generator/welder package

snorkel

Vigo Centre, Birtley Road,
Washington, Tyne & Wear,
NE38 9DA, U.K.

t: +44 (0) 845 1550 057

e: sales@snorkellifts.com

www.snorkellifts.com