

S3010E

SELF PROPELLED MINI SCISSOR LIFT



- Compact & lightweight electric mini scissor lift
- Can be driven at full height
- Zero inside turning radius
- Drives through a standard doorway
- Ideal for low-level interior installation and maintenance applications

 **snorkel**
www.snorkellifts.com

SELF PROPELLED MINI SCISSOR LIFT

S3010E

DIMENSIONS	S3010E
Max. working height	5.0m
Max. platform height (A)	3.0m
Platform size	1.09m x 0.51m
Overall width (B)	0.77m
Overall length (C)	1.26m
Stowed height (D)	1.8m
Ground clearance	58mm

PERFORMANCE	
Platform capacity (SWL)	227kg
Max. drive height	3.0m
Max. wind speed	0m/s
Max. drive speed (stowed)	3.5km/h
Max. drive speed (elevated)	0.64km/h
Raise/lower time	18/25 sec
Gradeability	25%
Max. operating slope	2°
Inside turning radius	0m
Outside turning radius	1.4m
Tyres	230mm dia. non-marking rubber
Parking brake	2 wheel automatic
Controls	2-axis proportional joystick
Drive system	DC direct drive

POWER	
Power source	2 x 12V 105Ah
Battery charger	100-240V 50/60Hz Auto, 30 amp

WEIGHT	
Weight	495kg

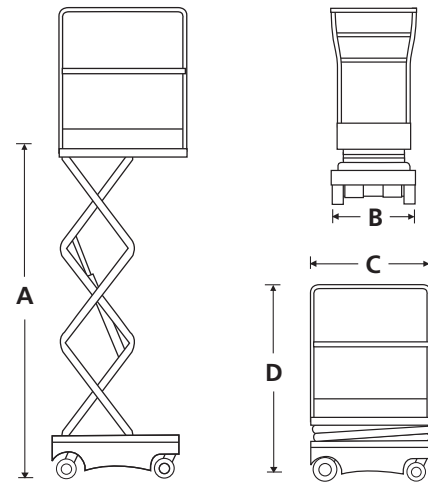

STANDARD FEATURES

- Highly manoeuvrable skid steer
- Zero inside turning radius
- Saloon-door style entry gates
- 1 person + equipment capacity indoor
- Non-marking tyres
- Proportional joystick controls
- Integrated battery charger
- Battery condition indicator
- Crane points & through-the-chassis fork pockets
- Selectable motion alarm
- Tilt & descent alarm
- Hour meter
- Horn
- 2 year parts & labour, 5 year structural warranty
- CE approved

OPTIONS

- Special paint colours

TURNING RADIUS

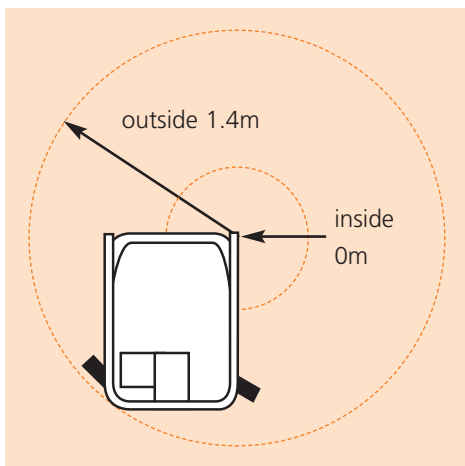

snorkel www.snorkellifts.com

Vigo Centre, Birtley Road,
Washington, Tyne & Wear,
NE38 9DA, U.K.

t: +44 (0) 845 1550 057
e: sales@snorkellifts.com